

**Problem 11.5-13** A frame  $ABCD$  is constructed of steel wide-flange members ( $W 8 \times 21$ ;  $E = 30 \times 10^6$  psi) and subjected to triangularly distributed loads of maximum intensity  $q_0$  acting along the vertical members (see figure). The distance between supports is  $L = 20$  ft and the height of the frame is  $h = 4$  ft. The members are rigidly connected at  $B$  and  $C$ .

(a) Calculate the intensity of load  $q_0$  required to produce a maximum bending moment of 80 k-in. in the horizontal member  $BC$ .

(b) If the load  $q_0$  is reduced to one-half of the value calculated in part (a), what is the maximum bending moment in member  $BC$ ? What is the ratio of this moment to the moment of 80 k-in. in part (a)?

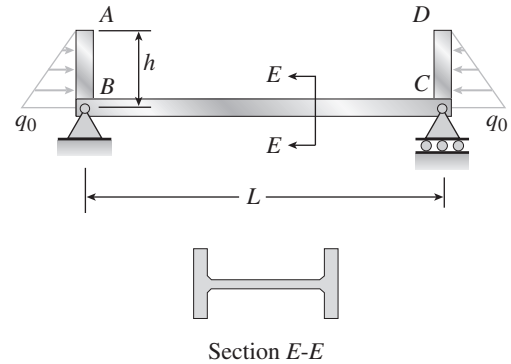

**Solution 11.5-13 Frame with triangular loads**

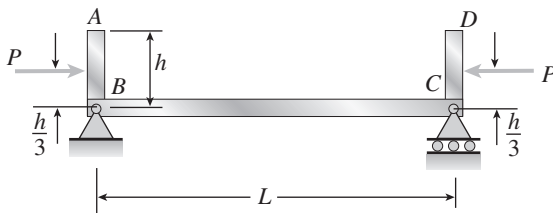

$P$  = resultant force  
 $e$  = eccentricity

$$P = \frac{q_0 h}{2} \quad e = \frac{h}{3}$$

MAXIMUM BENDING MOMENT IN BEAM  $BC$

From Eq. (11-56):  $M_{\max} = Pe \sec \frac{kL}{2}$

$$k = \sqrt{\frac{P}{EI}} \quad \therefore M_{\max} = Pe \sec \sqrt{\frac{PL^2}{4EI}} \quad (1)$$

NUMERICAL DATA

$W 8 \times 21 \quad I = I_2 = 9.77 \text{ in.}^4$  (from Table E-1)

$E = 30 \times 10^6 \text{ psi} \quad L = 20 \text{ ft} = 240 \text{ in.}$

$h = 4 \text{ ft} = 48 \text{ in.}$

$$e = \frac{h}{3} = 16 \text{ in.}$$

(a) LOAD  $q_0$  TO PRODUCE  $M_{\max} = 80$  k-in.

Substitute numerical values into Eq. (1).  
 Units: pounds and inches

$$M_{\max} = 80,000 \text{ lb-in.} \sqrt{\frac{PL^2}{4EI}}$$

$$= 0.0070093 \sqrt{P} \quad (\text{radians})$$

$$80,000 = P(16 \text{ in.}) [\sec(0.0070093 \sqrt{P})]$$

$$5,000 = P \sec(0.0070093 \sqrt{P})$$

$$P - 5,000 [\cos(0.0070093 \sqrt{P})] = 0 \quad (2)$$

SOLVE EQ. (2) NUMERICALLY

$$P = 4461.9 \text{ lb}$$

$$q_0 = \frac{2P}{h} = 186 \text{ lb/in.} = 2230 \text{ lb/ft} \quad \leftarrow$$

(b) LOAD  $q_0$  IS REDUCED TO ONE-HALF ITS VALUE

$\therefore P$  is reduced to one-half its value.

$$P = \frac{1}{2}(4461.9 \text{ lb}) = 2231.0 \text{ lb}$$

Substitute numerical values into Eq. (1) and solve for  $M_{\max}$ .

$$M_{\max} = 37.75 \text{ k-in.} \quad \leftarrow$$

$$\text{Ratio: } \frac{M_{\max}}{80 \text{ k-in.}} = 5 \frac{37.7}{80} = 0.47 \quad \leftarrow$$

This result shows that the bending moment varies nonlinearly with the load.

## The Secant Formula

When solving the problems for Section 11.6, assume that bending occurs in the principal plane containing the eccentric axial load.

**Problem 11.6-1** A steel bar has a square cross section of width  $b = 2.0$  in. (see figure). The bar has pinned supports at the ends and is 3.0 ft long. The axial forces acting at the end of the bar have a resultant  $P = 20$  k located at distance  $e = 0.75$  in. from the center of the cross section. Also, the modulus of elasticity of the steel is 29,000 ksi.

- (a) Determine the maximum compressive stress  $\sigma_{\max}$  in the bar.  
 (b) If the allowable stress in the steel is 18,000 psi, what is the maximum permissible length  $L_{\max}$  of the bar?

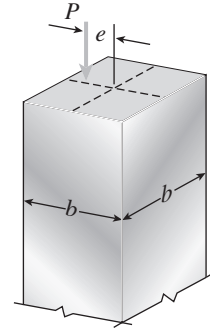

Probs. 11.6-1 through 11.6-3

### Solution 11.6-1 Bar with square cross section

Pinned supports.

DATA

$$b = 2.0 \text{ in.} \quad L = 3.0 \text{ ft} = 36 \text{ in.} \quad P = 20 \text{ k}$$

$$e = 0.75 \text{ in.} \quad E = 29,000 \text{ ksi}$$

(a) MAXIMUM COMPRESSIVE STRESS

Secant formula (Eq. 11-59):

$$\sigma_{\max} = \frac{P}{A} \left[ 1 + \frac{ec}{r^2} \sec \left( \frac{L}{2r} \sqrt{\frac{P}{EA}} \right) \right] \quad (1)$$

$$\frac{P}{A} = \frac{P}{b^2} = 5.0 \text{ ksi} \quad c = \frac{b}{2} = 1.0 \text{ in.}$$

$$I = \frac{b^4}{12} = 1.333 \text{ in.}^4 \quad r^2 = \frac{I}{A} = 0.3333 \text{ in.}^2$$

$$\frac{ec}{r^2} = 2.25 \quad \frac{L}{r} = 62.354 \quad \frac{P}{EA} = 0.00017241$$

Substitute into Eq. (1):

$$\sigma_{\max} = 17.3 \text{ ksi} \quad \leftarrow$$

(b) MAXIMUM PERMISSIBLE LENGTH

$$\sigma_{\text{allow}} = 18,000 \text{ psi}$$

Solve Eq. (1) for the length  $L$ :

$$L = 2 \sqrt{\frac{EI}{P}} \arccos \left[ \frac{P(ec/r^2)}{\sigma_{\max} A - P} \right] \quad (2)$$

Substitute numerical values:

$$L_{\max} = 46.2 \text{ in.} \quad \leftarrow$$

**Problem 11.6-2** A brass bar ( $E = 100$  GPa) with a square cross section is subjected to axial forces having a resultant  $P$  acting at distance  $e$  from the center (see figure). The bar is pin supported at the ends and is 0.6 m in length. The side dimension  $b$  of the bar is 30 mm and the eccentricity  $e$  of the load is 10 mm.

If the allowable stress in the brass is 150 MPa, what is the allowable axial force  $P_{\text{allow}}$ ?

### Solution 11.6-2 Bar with square cross section

Pinned supports.

DATA

$$b = 30 \text{ mm} \quad L = 0.6 \text{ m} \quad \sigma_{\text{allow}} = 150 \text{ MPa}$$

$$e = 10 \text{ mm} \quad E = 100 \text{ GPa}$$

SECANT FORMULA (Eq. 11-59):

$$\sigma_{\max} = \frac{P}{A} \left[ 1 + \frac{ec}{r^2} \sec \left( \frac{L}{2r} \sqrt{\frac{P}{EA}} \right) \right] \quad (1)$$

Units: Newtons and meters

$$\sigma_{\max} = 150 \times 10^6 \text{ N/m}^2$$

$$A = b^2 = 900 \times 10^{-6} \text{ m}^2$$

$$c = \frac{b}{2} = 0.015 \text{ m} \quad r^2 = \frac{I}{A} = \frac{b^2}{12} = 75 \times 10^{-6} \text{ m}^2$$

$$\frac{ec}{r^2} = 2.0 \quad P = \text{newtons} \quad \frac{L}{2r} \sqrt{\frac{P}{EA}} = 0.0036515 \sqrt{P}$$

SUBSTITUTE NUMERICAL VALUES INTO Eq. (1):

$$150 \times 10^6 = \frac{P}{900 \times 10^{-6}} [1 + 2 \sec(0.0036515 \sqrt{P})]$$

or

$$P[1 + 2 \sec(0.0036515 \sqrt{P})] - 135,000 = 0 \quad (2)$$

SOLVE EQ. (2) NUMERICALLY:

$$P_{\text{allow}} = 37,200 \quad N = 37.2 \text{ kN} \quad \leftarrow$$

**Problem 11.6-3** A square aluminum bar with pinned ends carries a load  $P = 25 \text{ k}$  acting at distance  $e = 2.0 \text{ in.}$  from the center (see figure on the previous page). The bar has length  $L = 54 \text{ in.}$  and modulus of elasticity  $E = 10,600 \text{ ksi.}$

If the stress in the bar is not to exceed  $6 \text{ ksi}$ , what is the minimum permissible width  $b_{\min}$  of the bar?

### Solution 11.6-3 Square aluminum bar

Pinned ends

DATA

Units: pounds and inches

$$P = 25 \text{ k} = 25,000 \text{ psi} \quad e = 2.0 \text{ in.}$$

$$L = 54 \text{ in.} \quad E = 10,600 \text{ ksi} = 10,600,000 \text{ psi}$$

$$\sigma_{\max} = 6.0 \text{ ksi} = 6,000 \text{ psi}$$

SECANT FORMULA (Eq. 11-59)

$$\sigma_{\max} = \frac{P}{A} \left[ 1 + \frac{ec}{r^2} \sec \left( \frac{L}{2r} \sqrt{\frac{P}{EA}} \right) \right] \quad (1)$$

$$A = b^2 \quad c = \frac{b}{2} \quad r^2 = \frac{I}{A} = \frac{b^2}{12}$$

$$\frac{ec}{r^2} = \frac{12}{b} \quad \frac{L}{2r} \sqrt{\frac{P}{EA}} = \frac{4.5423}{b^2}$$

SUBSTITUTE TERMS INTO EQ. (1):

$$6,000 = \frac{25,000}{b^2} \left[ 1 + \frac{12}{b} \sec \left( \frac{4.5423}{b^2} \right) \right]$$

or

$$1 + \frac{12}{b} \sec \left( \frac{4.5423}{b^2} \right) - 0.24 b^2 = 0 \quad (2)$$

SOLVE EQ. (2) NUMERICALLY:

$$b_{\min} = 4.10 \text{ in.} \quad \leftarrow$$

**Problem 11.6-4** A pinned-end column of length  $L = 2.1 \text{ m}$  is constructed of steel pipe ( $E = 210 \text{ GPa}$ ) having inside diameter  $d_1 = 60 \text{ mm}$  and outside diameter  $d_2 = 68 \text{ mm}$  (see figure). A compressive load  $P = 10 \text{ kN}$  acts with eccentricity  $e = 30 \text{ mm}$ .

(a) What is the maximum compressive stress  $\sigma_{\max}$  in the column?

(b) If the allowable stress in the steel is  $50 \text{ MPa}$ , what is the maximum permissible length  $L_{\max}$  of the column?

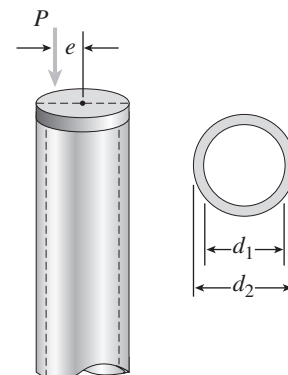

Probs. 11.6-4 through 11.6-6

**Solution 11.6-4 Steel pipe column**

Pinned ends.

DATA Units: Newtons and meters

$$L = 2.1 \text{ m} \quad E = 210 \text{ GPa} = 210 \times 10^9 \text{ N/m}^2$$

$$d_1 = 60 \text{ mm} = 0.06 \text{ m} \quad d_2 = 68 \text{ mm} = 0.068 \text{ m}$$

$$P = 10 \text{ kN} = 10,000 \text{ N} \quad e = 30 \text{ mm} = 0.03 \text{ m}$$

TUBULAR CROSS SECTION

$$A = \frac{\pi}{4}(d_2^2 - d_1^2) = 804.25 \times 10^{-6} \text{ m}^2$$

$$I = \frac{\pi}{64}(d_2^4 - d_1^4) = 413.38 \times 10^{-9} \text{ m}^4$$

(a) MAXIMUM COMPRESSIVE STRESS

Secant formula (Eq. 11-59):

$$\sigma_{\max} = \frac{P}{A} \left[ 1 + \frac{ec}{r^2} \sec \left( \frac{L}{2r} \sqrt{\frac{P}{EA}} \right) \right] \quad (1)$$

$$\frac{P}{A} = 12.434 \times 10^6 \text{ N/m}^2$$

$$r^2 = \frac{I}{A} = 513.99 \times 10^{-6} \text{ m}^2$$

$$r = 22.671 \times 10^{-3} \text{ m} \quad c = \frac{d_2}{2} = 0.034 \text{ m}$$

$$\frac{ec}{r^2} = 1.9845 \quad \frac{L}{2r} \sqrt{\frac{P}{EA}} = 0.35638$$

Substitute into Eq. (1):

$$\sigma_{\max} = 38.8 \times 10^6 \text{ N/m}^2 = 38.8 \text{ MPa} \quad \leftarrow$$

(b) MAXIMUM PERMISSIBLE LENGTH

$$\sigma_{\text{allow}} = 50 \text{ MPa}$$

Solve Eq. (1) for the length  $L$ :

$$L = 2\sqrt{\frac{EI}{P}} \arccos \left[ \frac{P(ec/r^2)}{\sigma_{\max} A - P} \right] \quad (2)$$

Substitute numerical values:

$$L_{\max} = 5.03 \text{ m} \quad \leftarrow$$

**Problem 11.6-5** A pinned-end strut of length  $L = 5.2$  ft is constructed of steel pipe ( $E = 30 \times 10^3$  ksi) having inside diameter  $d_1 = 2.0$  in. and outside diameter  $d_2 = 2.2$  in. (see figure). A compressive load  $P = 2.0$  k is applied with eccentricity  $e = 1.0$  in.

(a) What is the maximum compressive stress  $\sigma_{\max}$  in the strut?(b) What is the allowable load  $P_{\text{allow}}$  if a factor of safety  $n = 2$  with respect to yielding is required? (Assume that the yield stress  $\sigma_Y$  of the steel is 42 ksi.)**Solution 11.6-5 Pinned-end strut**

Steel pipe.

DATA Units: kips and inches

$$L = 5.2 \text{ ft} = 62.4 \text{ in.} \quad E = 30 \times 10^3 \text{ ksi}$$

$$d_1 = 2.0 \text{ in.} \quad d_2 = 2.2 \text{ in.}$$

$$P = 2.0 \text{ k} \quad e = 1.0 \text{ in.}$$

TUBULAR CROSS SECTION

$$A = \frac{\pi}{4}(d_2^2 - d_1^2) = 0.65973 \text{ in.}^2$$

$$I = \frac{\pi}{64}(d_2^4 - d_1^4) = 0.36450 \text{ in.}^4$$

(a) MAXIMUM COMPRESSIVE STRESS

Secant formula (Eq. 11-59):

$$\sigma_{\max} = \frac{P}{A} \left[ 1 + \frac{ec}{r^2} \sec \left( \frac{L}{2r} \sqrt{\frac{P}{EA}} \right) \right] \quad (1)$$

$$\frac{P}{A} = 3.0315 \text{ ksi} \quad c = \frac{d_2}{2} = 1.1 \text{ in.}$$

$$r^2 = \frac{I}{A} = 0.55250 \text{ in.}^2 \quad \frac{ec}{r^2} = 1.9910$$

$$r = 0.74330 \text{ in.} \quad \frac{L}{2r} \sqrt{\frac{P}{EA}} = 0.42195$$

Substitute into Eq. (1):

$$\sigma_{\max} = 9.65 \text{ ksi} \quad \leftarrow$$

(b) ALLOWABLE LOAD

$$\sigma_Y = 42 \text{ ksi} \quad n = 2 \quad \text{find } P_{\text{allow}}$$

Substitute numerical values into Eq. (1):

$$42 = \frac{P}{0.65973} [1 + 1.9910 \sec(0.29836 \sqrt{P})] \quad (2)$$

Solve Eq. (2) numerically:  $P = P_Y = 7.184 \text{ k}$ 

$$P_{\text{allow}} = \frac{P_Y}{n} = 3.59 \text{ k} \quad \leftarrow$$

**Problem 11.6-6** A circular aluminum tube with pinned ends supports a load  $P = 18$  kN acting at distance  $e = 50$  mm from the center (see figure). The length of the tube is 3.5 m and its modulus of elasticity is 73 GPa.

If the maximum permissible stress in the tube is 20 MPa, what is the required outer diameter  $d_2$  if the ratio of diameters is to be  $d_1/d_2 = 0.9$ ?

**Solution 11.6-6 Aluminum tube**

Pinned ends.

DATA  $P = 18$  kN  $e = 50$  mm

$L = 3.5$  m  $E = 73$  GPa

$\sigma_{\max} = 20$  MPa  $d_1/d_2 = 0.9$

SECANT FORMULA (EQ. 11-59)

$$\sigma_{\max} = \frac{P}{A} \left[ 1 + \frac{ec}{r^2} \sec \left( \frac{L}{2r} \sqrt{\frac{P}{EA}} \right) \right] \quad (1)$$

$$A = \frac{\pi}{4}(d_2^2 - d_1^2) = \frac{\pi}{4}[d_2^2 - (0.9d_2)^2] = 0.14923 d_2^2$$

( $d_2 = \text{mm}$ ;  $A = \text{mm}^2$ )

$$\frac{P}{A} = \frac{18,000 \text{ N}}{0.14923 d_2^2} = \frac{120,620}{d_2^2} \left( \frac{P}{A} = \text{MPa} \right)$$

$$I = \frac{\pi}{64}(d_2^4 - d_1^4) = \frac{\pi}{64}[d_2^4 - (0.9d_2)^4] = 0.016881 d_2^4$$

( $d_2 = \text{mm}$ ;  $I = \text{mm}^4$ )

$$r^2 = \frac{I}{A} = 0.11313 d_2^2 \quad (d_2 = \text{mm}; r^2 = \text{mm}^2)$$

$r = 0.33634 d_2$  ( $r = \text{mm}$ )

$$c = \frac{d_2}{2} \quad \frac{ec}{r^2} = \frac{(50 \text{ mm})(d_2/2)}{0.11313 d_2^2} = \frac{220.99}{d_2}$$

$$\frac{L}{2r} = \frac{3500 \text{ mm}}{2(0.33634 d_2)} = \frac{5,203.1}{d_2}$$

$$\frac{P}{EA} = \frac{18,000 \text{ N}}{(73,000 \text{ N/mm}^2)(0.14923 d_2^2)} = \frac{1.6524}{d_2^2}$$

$$\frac{L}{2r} \sqrt{\frac{P}{EA}} = \frac{5,203.1}{d_2} \sqrt{\frac{1.6524}{d_2^2}} = \frac{6688.2}{d_2^2}$$

SUBSTITUTE THE ABOVE EXPRESSIONS INTO EQ. (1):

$$\sigma_{\max} = 20 \text{ MPa} = \frac{120,620}{d_2^2} + \left[ 1 + \frac{220.99}{d_2} \sec \left( \frac{6688.2}{d_2^2} \right) \right] \quad (2)$$

SOLVE EQ. (2) NUMERICALLY:

$$d_2 = 131 \text{ mm} \quad \leftarrow$$

**Problem 11.6-7** A steel column ( $E = 30 \times 10^3$  ksi) with pinned ends is constructed of a W 10  $\times$  60 wide-flange shape (see figure). The column is 24 ft long. The resultant of the axial loads acting on the column is a force  $P$  acting with an eccentricity  $e = 2.0$  in.

(a) If  $P = 120$  k, determine the maximum compressive stress  $\sigma_{\max}$  in the column.

(b) Determine the allowable load  $P_{\text{allow}}$  if the yield stress is  $\sigma_Y = 42$  ksi and the factor of safety with respect to yielding of the material is  $n = 2.5$ .

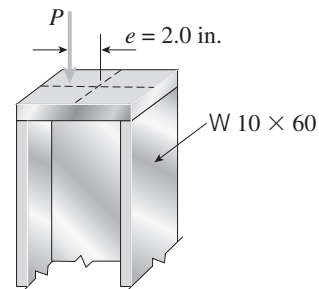

**Solution 11.6-7 Steel column with pinned ends**

$$E = 30 \times 10^3 \text{ ksi} \quad L = 24 \text{ ft} = 288 \text{ in.}$$

$$e = 2.0 \text{ in.}$$

W 10 × 60 wide-flange shape

$$A = 17.6 \text{ in.}^2 \quad I = 341 \text{ in.}^4 \quad d = 10.22 \text{ in.}$$

$$r^2 = \frac{I}{A} = 19.38 \text{ in.}^2 \quad r = 4.402 \text{ in.} \quad c = \frac{d}{2} = 5.11 \text{ in.}$$

$$\frac{L}{r} = 65.42 \quad \frac{ec}{r^2} = 0.5273$$

(a) MAXIMUM COMPRESSIVE STRESS ( $P = 120 \text{ k}$ )

Secant formula (Eq. 11-59):

$$\sigma_{\max} = \frac{P}{A} \left[ 1 + \frac{ec}{r^2} \sec \left( \frac{L}{2r} \sqrt{\frac{P}{EA}} \right) \right] \quad (1)$$

$$\frac{P}{A} = 6.818 \text{ ksi} \quad \frac{L}{2r} \sqrt{\frac{P}{EA}} = 0.4931$$

$$\text{Substitute into Eq. (1): } \sigma_{\max} = 10.9 \text{ ksi} \quad \leftarrow$$

(b) ALLOWABLE LOAD

$$\sigma_Y = 42 \text{ ksi} \quad n = 2.5 \quad \text{find } P_{\text{allow}}$$

Substitute into Eq. (1):

$$42 = \frac{P}{17.6} [1 + 0.5273 \sec(0.04502 \sqrt{P})]$$

Solve numerically:  $P = P_Y = 399.9 \text{ k}$

$$P_{\text{allow}} = P_Y/n = 160 \text{ k} \quad \leftarrow$$

**Problem 11.6-8** A W 16 × 57 steel column is compressed by a force  $P = 75 \text{ k}$  acting with an eccentricity  $e = 1.5 \text{ in.}$ , as shown in the figure. The column has pinned ends and length  $L$ . Also, the steel has modulus of elasticity  $E = 30 \times 10^3 \text{ ksi}$  and yield stress  $\sigma_Y = 36 \text{ ksi}$ .

(a) If the length  $L = 10 \text{ ft}$ , what is the maximum compressive stress  $\sigma_{\max}$  in the column?

(b) If a factor of safety  $n = 2.0$  is required with respect to yielding, what is the longest permissible length  $L_{\max}$  of the column?

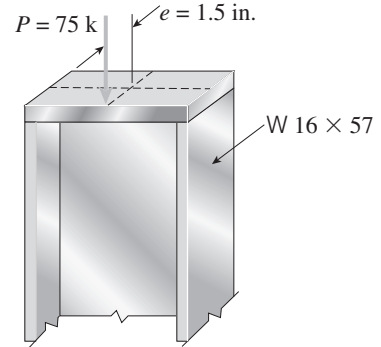
**Solution 11.6-8 Steel column with pinned ends**

$$W 16 \times 57 \quad A = 16.8 \text{ in.}^2 \quad I = I_2 = 43.1 \text{ in.}^4$$

$$b = 7.120 \text{ in.}$$

$$c = b/2 = 3.560 \text{ in.}$$

$$e = 1.5 \text{ in.} \quad r^2 = \frac{I}{A} = 2.565 \text{ in.}^2$$

$$\frac{ec}{r^2} = 2.082 \quad r = 1.602 \text{ in.}$$

$$P = 75 \text{ k} \quad E = 30 \times 10^3 \text{ ksi} \quad \frac{P}{EA} = 148.8 \times 10^{-6}$$

(a) MAXIMUM COMPRESSIVE STRESS

Secant formula (Eq. 11-59):

$$\sigma_{\max} = \frac{P}{A} \left[ 1 + \frac{ec}{r^2} \sec \left( \frac{L}{2r} \sqrt{\frac{P}{EA}} \right) \right] \quad (1)$$

$$L = 10 \text{ ft} = 120 \text{ in.}$$

$$\frac{P}{A} = 4.464 \text{ ksi} \quad \frac{L}{2r} \sqrt{\frac{P}{EA}} = 0.4569$$

Substitute into Eq. (1):

$$\sigma_{\max} = 4.464 [1 + 2.082 \sec(0.4569)] = 14.8 \text{ ksi} \quad \leftarrow$$

(b) MAXIMUM LENGTH

Solve Eq. (1) for the length  $L$ :

$$L = 2 \sqrt{\frac{EI}{P}} \arccos \left[ \frac{P(ec/r^2)}{\sigma_{\max} A - P} \right] \quad (2)$$

$$\sigma_Y = 36 \text{ ksi} \quad n = 2.0 \quad P_Y = n P = 150 \text{ k}$$

Substitute  $P_Y$  for  $P$  and  $\sigma_Y$  for  $\sigma_{\max}$  in Eq. (2):

$$L_{\max} = 2 \sqrt{\frac{EI}{P_Y}} \arccos \left[ \frac{P_Y(ec/r^2)}{\sigma_Y A - P_Y} \right] \quad (3)$$

Substitute numerical values in Eq. (3) and solve for  $L_{\max}$ :

$$L_{\max} = 151.1 \text{ in.} = 12.6 \text{ ft} \quad \leftarrow$$

**Problem 11.6-9** A steel column ( $E = 30 \times 10^3$  ksi) that is fixed at the base and free at the top is constructed of a  $W 8 \times 35$  wide-flange member (see figure). The column is 9.0 ft long. The force  $P$  acting at the top of the column has an eccentricity  $e = 1.25$  in.

(a) If  $P = 40$  k, what is the maximum compressive stress in the column?

(b) If the yield stress is 36 ksi and the required factor of safety with respect to yielding is 2.1, what is the allowable load  $P_{\text{allow}}$ ?

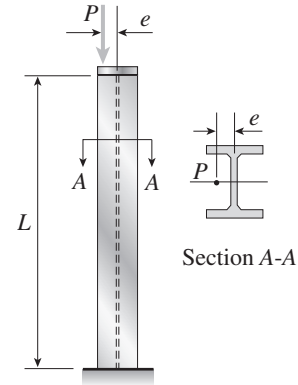

**Probs. 11.6-9 and 11.6-10**

**Solution 11.6-9 Steel column (fixed-free)**

$$E = 30 \times 10^3 \text{ ksi} \quad e = 1.25 \text{ in.}$$

$$Le = 2L = 2(9.0 \text{ ft}) = 18 \text{ ft} = 216 \text{ in.}$$

$$W 8 \times 35 \text{ WIDE-FLANGE SHAPE}$$

$$A = 10.3 \text{ in.}^2 \quad I = I_2 = 42.6 \text{ in.}^4 \quad b = 8.020 \text{ in.}$$

$$r^2 = \frac{I}{A} = 4.136 \text{ in.}^2 \quad r = 2.034 \text{ in.}$$

$$c = \frac{b}{2} = 4.010 \text{ in.} \quad \frac{Le}{r} = 106.2 \quad \frac{ec}{r^2} = 1.212$$

(a) MAXIMUM COMPRESSIVE STRESS ( $P = 40$  k)

Secant formula (Eq. 11-59):

$$\sigma_{\text{max}} = \frac{P}{A} \left[ 1 + \frac{ec}{r^2} \sec \left( \frac{Le}{2r} \sqrt{\frac{P}{EA}} \right) \right] \quad (1)$$

$$\frac{P}{A} = 3.883 \text{ ksi} \quad \frac{Le}{2r} \sqrt{\frac{P}{EA}} = 0.6042$$

$$\text{Substitute into Eq. (1):} \quad \sigma_{\text{max}} = 9.60 \text{ ksi} \quad \leftarrow$$

(b) ALLOWABLE LOAD

$$\sigma_Y = 36 \text{ ksi} \quad n = 2.1 \quad \text{find } P_{\text{allow}}$$

Substitute into Eq. (1):

$$36 = \frac{P}{10.3} [1 + 1.212 \sec(0.09552 \sqrt{P})]$$

$$\text{Solve numerically:} \quad P = P_Y = 112.6 \text{ k}$$

$$P_{\text{allow}} = P_Y/n = 53.6 \text{ k} \quad \leftarrow$$

**Problem 11.6-10** A  $W 12 \times 50$  wide-flange steel column with length  $L = 12.5$  ft is fixed at the base and free at the top (see figure). The load  $P$  acting on the column is intended to be centrally applied, but because of unavoidable discrepancies in construction, an eccentricity ratio of 0.25 is specified. Also, the following data are supplied:  $E = 30 \times 10^3$  ksi,  $\sigma_Y = 42$  ksi, and  $P = 70$  k.

(a) What is the maximum compressive stress  $\sigma_{\text{max}}$  in the column?

(b) What is the factor of safety  $n$  with respect to yielding of the steel?

**Solution 11.6-10 Steel column (fixed-free)**

$$E = 30 \times 10^3 \text{ ksi} \quad \frac{ec}{r^2} = 0.25$$

$$Le = 2L = 2(12.5 \text{ ft}) = 25 \text{ ft} = 300 \text{ in.}$$

$$W 12 \times 50 \text{ WIDE-FLANGE SHAPE}$$

$$A = 14.7 \text{ in.}^2 \quad I = I_2 = 56.3 \text{ in.}^4$$

$$r^2 = \frac{I}{A} = 3.830 \text{ in.}^2 \quad r = 1.957 \text{ in.}$$

(a) MAXIMUM COMPRESSIVE STRESS ( $P = 70$  k)

Secant formula (Eq. 11-59):

$$\sigma_{\text{max}} = \frac{P}{A} \left[ 1 + \frac{ec}{r^2} \sec \left( \frac{Le}{2r} \sqrt{\frac{P}{EA}} \right) \right] \quad (1)$$

$$\frac{P}{A} = 4.762 \text{ ksi} \quad \frac{Le}{2r} \sqrt{\frac{P}{EA}} = 0.9657$$

Substitute into Eq. (1):  $\sigma_{\max} = 6.85 \text{ ksi}$  ←

(b) FACTOR OF SAFETY WITH RESPECT TO YIELDING

$$\sigma_Y = 42 \text{ psi}$$

Substitute into Eq. (1) with  $\sigma_{\max} = \sigma_Y$  and  $P = P_Y$ :

$$42 = \frac{P_Y}{A} [1 + 0.25 \sec(0.1154 \sqrt{P_Y})]$$

Solve numerically:  $P_Y = 164.5 \text{ k}$

$$P = 70 \text{ k} \quad n = \frac{P_Y}{P} = \frac{164.5 \text{ k}}{70 \text{ k}} = 2.35 \quad \leftarrow$$

**Problem 11.6-11** A pinned-end column with length  $L = 18 \text{ ft}$  is constructed from a  $W 12 \times 87$  wide-flange shape (see figure). The column is subjected to a centrally applied load  $P_1 = 180 \text{ k}$  and an eccentrically applied load  $P_2 = 75 \text{ k}$ . The load  $P_2$  acts at distance  $s = 5.0 \text{ in.}$  from the centroid of the cross section. The properties of the steel are  $E = 29,000 \text{ ksi}$  and  $\sigma_Y = 36 \text{ ksi}$ .

- (a) Calculate the maximum compressive stress in the column.  
 (b) Determine the factor of safety with respect to yielding.

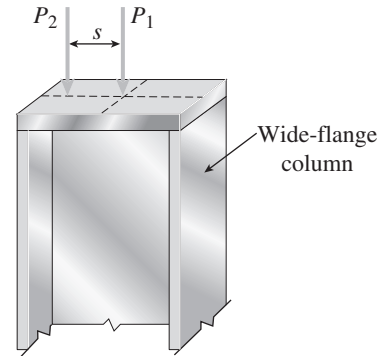

Probs. 11.6.11 and 11.6.12

**Solution 11.6-11 Column with two loads**

Pinned-end column.  $W 12 \times 87$

DATA

$$L = 18 \text{ ft} = 216 \text{ in.}$$

$$P_1 = 180 \text{ k} \quad P_2 = 75 \text{ k} \quad s = 5.0 \text{ in.}$$

$$E = 29,000 \text{ ksi} \quad \sigma_Y = 36 \text{ ksi}$$

$$P = P_1 + P_2 = 255 \text{ k} \quad e = \frac{P_2 s}{P} = 1.471 \text{ in.}$$

$$A = 25.6 \text{ in.}^2 \quad I = I_1 = 740 \text{ in.}^4 \quad d = 12.53 \text{ in.}$$

$$r^2 = \frac{I}{A} = 28.91 \text{ in.}^2 \quad r = 5.376 \text{ in.}$$

$$c = \frac{d}{2} = 6.265 \text{ in.} \quad \frac{ec}{r^2} = 0.3188$$

$$\frac{P}{A} = 9.961 \text{ ksi} \quad \frac{L}{2r} \sqrt{\frac{P}{EA}} = 0.3723$$

(a) MAXIMUM COMPRESSIVE STRESS

Secant formula (Eq. 11-59):

$$\sigma_{\max} = \frac{P}{A} \left[ 1 + \frac{ec}{r^2} \sec \left( \frac{L}{2r} \sqrt{\frac{P}{EA}} \right) \right] \quad (1)$$

Substitute into Eq. (1):  $\sigma_{\max} = 13.4 \text{ ksi}$  ←

(b) FACTOR OF SAFETY WITH RESPECT TO YIELDING

$$\sigma_{\max} = \sigma_Y = 36 \text{ ksi} \quad P = P_Y$$

Substitute into Eq. (1):

$$36 = \frac{P_Y}{25.6} [1 + 0.3188 \sec(0.02332 \sqrt{P_Y})]$$

Solve numerically:  $P_Y = 664.7 \text{ k}$

$$P = 255 \text{ k} \quad n = \frac{P_Y}{P} = \frac{664.7 \text{ k}}{255 \text{ k}} = 2.61 \quad \leftarrow$$

**Problem 11.6-12** The wide-flange pinned-end column shown in the figure carries two loads, a force  $P_1 = 100$  k acting at the centroid and a force  $P_2 = 60$  k acting at distance  $s = 4.0$  in. from the centroid. The column is a W 10  $\times$  45 shape with  $L = 13.5$  ft,  $E = 29 \times 10^3$  ksi, and  $\sigma_Y = 42$  ksi.

(a) What is the maximum compressive stress in the column?

(b) If the load  $P_1$  remains at 100 k, what is the largest permissible value of the load  $P_2$  in order to maintain a factor of safety of 2.0 with respect to yielding?

**Solution 11.6-12 Column with two loads**

Pinned-end column. W 10  $\times$  45

DATA

$$L = 13.5 \text{ ft} = 162 \text{ in.}$$

$$P_1 = 100 \text{ k} \quad P_2 = 60 \text{ k} \quad s = 4.0 \text{ in.}$$

$$E = 29,000 \text{ ksi} \quad \sigma_Y = 42 \text{ ksi}$$

$$P = P_1 + P_2 = 160 \text{ k} \quad e = \frac{P_2 s}{P} = 1.50 \text{ in.}$$

$$A = 13.3 \text{ in.}^2 \quad I = I_1 = 248 \text{ in.}^4 \quad d = 10.10 \text{ in.}$$

$$r^2 = \frac{I}{A} = 18.65 \text{ in.}^2 \quad r = 4.318 \text{ in.}$$

$$c = \frac{d}{2} = 5.05 \text{ in.} \quad \frac{ec}{r^2} = 0.4062$$

$$\frac{P}{A} = 12.03 \text{ ksi} \quad \frac{L}{2r} \sqrt{\frac{P}{EA}} = 0.3821$$

(a) MAXIMUM COMPRESSIVE STRESS

Secant formula (Eq. 11-59):

$$\sigma_{\max} = \frac{P}{A} \left[ 1 + \frac{ec}{r^2} \sec \left( \frac{L}{2r} \sqrt{\frac{P}{EA}} \right) \right] \quad (1)$$

Substitute into Eq. (1):  $\sigma_{\max} = 17.3$  ksi ←

(b) LARGEST VALUE OF LOAD  $P_2$

$$P_1 = 100 \text{ k (no change)}$$

$$n = 2.0 \text{ with respect to yielding}$$

Units: kips, inches

$$P = P_1 + P_2 = 100 + P_2$$

$$e = \frac{P_2 s}{P} = \frac{P_2(4.0)}{100 + P_2} \quad \frac{ec}{r^2} = \frac{1.0831 P_2}{100 + P_2}$$

$$\sigma_{\max} = \sigma_Y = 42 \text{ ksi} \quad P_Y = n P = 2.0(100 + P_2)$$

Use Eq. (1) with  $\sigma_{\max}$  replaced by  $\sigma_Y$  and  $P$  replaced by  $P_Y$ :

$$\sigma_Y = \frac{P_Y}{A} \left[ 1 + \frac{ec}{r^2} \sec \left( \frac{L}{2r} \sqrt{\frac{P_Y}{EA}} \right) \right] \quad (2)$$

Substitute into Eq. (2):

$$42 = \frac{2.0(100 + P_2)}{13.3}$$

$$\left[ 1 + \frac{1.0831 P_2}{100 + P_2} \sec (0.04272 \sqrt{100 + P_2}) \right]$$

Solve numerically:  $P_2 = 78.4$  k ←

**Problem 11.6-13** A W 14  $\times$  53 wide-flange column of length  $L = 15$  ft is fixed at the base and free at the top (see figure). The column supports a centrally applied load  $P_1 = 120$  k and a load  $P_2 = 40$  k supported on a bracket. The distance from the centroid of the column to the load  $P_2$  is  $s = 12$  in. Also, the modulus of elasticity is  $E = 29,000$  ksi and the yield stress is  $\sigma_Y = 36$  ksi.

(a) Calculate the maximum compressive stress in the column.

(b) Determine the factor of safety with respect to yielding.

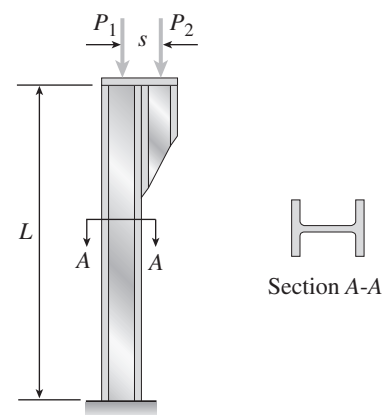

Probs. 11.6-13 and 11.6-14

**Solution 11.6-13 Column with two loads**

Fixed-free column. W 14 × 53

DATA

$$L = 15 \text{ ft} = 180 \text{ in.} \quad L_e = 2L = 360 \text{ in.}$$

$$P_1 = 120 \text{ k} \quad P_2 = 40 \text{ k} \quad s = 12 \text{ in.}$$

$$E = 29,000 \text{ ksi} \quad \sigma_Y = 36 \text{ ksi}$$

$$P = P_1 + P_2 = 160 \text{ k} \quad e = \frac{P_2 s}{P} = 3.0 \text{ in.}$$

$$A = 15.6 \text{ in.}^2 \quad I = I_1 = 541 \text{ in.}^4 \quad d = 13.92 \text{ in.}$$

$$r^2 = \frac{I}{A} = 34.68 \text{ in.}^2 \quad r = 5.889 \text{ in.}$$

$$c = \frac{d}{2} = 6.960 \text{ in.} \quad \frac{ec}{r^2} = 0.6021$$

$$\frac{P}{A} = 10.26 \text{ ksi} \quad \frac{L_e}{2r} \sqrt{\frac{P}{EA}} = 0.5748$$

(a) MAXIMUM COMPRESSIVE STRESS

Secant formula (Eq. 11-59):

$$\sigma_{\max} = \frac{P}{A} \left[ 1 + \frac{ec}{r^2} \sec \left( \frac{L_e}{2r} \sqrt{\frac{P}{EA}} \right) \right] \quad (1)$$

Substitute into Eq. (1):  $\sigma_{\max} = 17.6 \text{ ksi}$  ←

(b) FACTOR OF SAFETY WITH RESPECT TO YIELDING

$$\sigma_{\max} = \sigma_Y = 36 \text{ ksi} \quad P = P_Y$$

Substitute into Eq. (1):

$$36 = \frac{P_Y}{15.6} \left[ 1 + 0.6021 \sec(0.04544 \sqrt{P_Y}) \right]$$

Solve numerically:  $P_Y = 302.6 \text{ k}$ 

$$P = 160 \text{ k} \quad n = \frac{P_Y}{P} = \frac{302.6 \text{ k}}{160 \text{ k}} = 1.89 \quad \leftarrow$$

**Problem 11.6-14** A wide-flange column with a bracket is fixed at the base and free at the top (see figure on the preceding page). The column supports a load  $P_1 = 75 \text{ k}$  acting at the centroid and a load  $P_2 = 25 \text{ k}$  acting on the bracket at distance  $s = 10.0 \text{ in.}$  from the load  $P_1$ . The column is a W 12 × 35 shape with  $L = 16 \text{ ft}$ ,  $E = 29 \times 10^3 \text{ ksi}$ , and  $\sigma_Y = 42 \text{ ksi}$ .

(a) What is the maximum compressive stress in the column?

(b) If the load  $P_1$  remains at 75 k, what is the largest permissible value of the load  $P_2$  in order to maintain a factor of safety of 1.8 with respect to yielding?**Solution 11.6-14 Column with two loads**

Fixed-free column. W 12 × 35

DATA

$$L = 16 \text{ ft} = 192 \text{ in.} \quad L_e = 2L = 384 \text{ in.}$$

$$P_1 = 75 \text{ k} \quad P_2 = 25 \text{ k} \quad s = 10.0 \text{ in.}$$

$$E = 29,000 \text{ ksi} \quad \sigma_Y = 42 \text{ ksi}$$

$$P = P_1 + P_2 = 100 \text{ k} \quad e = \frac{P_2 s}{P} = 2.5 \text{ in.}$$

$$A = 10.3 \text{ in.}^2 \quad I = I_1 = 285 \text{ in.}^4 \quad d = 12.50 \text{ in.}$$

$$r^2 = \frac{I}{A} = 27.67 \text{ in.}^2 \quad r = 5.260 \text{ in.}$$

$$c = \frac{d}{2} = 6.25 \text{ in.} \quad \frac{ec}{r^2} = 0.5647$$

$$\frac{P}{A} = 9.709 \text{ ksi} \quad \frac{L_e}{2r} \sqrt{\frac{P}{EA}} = 0.6679$$

(a) MAXIMUM COMPRESSIVE STRESS

Secant formula (Eq. 11-59):

$$\sigma_{\max} = \frac{P}{A} \left[ 1 + \frac{ec}{r^2} \sec \left( \frac{L_e}{2r} \sqrt{\frac{P}{EA}} \right) \right] \quad (1)$$

Substitute into Eq. (1):  $\sigma_{\max} = 16.7 \text{ ksi}$  ←(b) LARGEST VALUE OF LOAD  $P_2$ 

$$P_1 = 75 \text{ k (no change)}$$

$$m = 1.8 \text{ with respect to yielding}$$

Units: kips, inches

$$P = P_1 + P_2 = 75 + P_2$$

$$e = \frac{P_2 s}{P} = \frac{P_2(10.0)}{75 + P_2} \quad \frac{ec}{r^2} = \frac{2.259 P_2}{75 + P_2}$$

$$\sigma_{\max} = \sigma_Y = 42 \text{ ksi} \quad P_Y = nP = 1.8(75 + P_2)$$

Use Eq. (1) with  $\sigma_{\max}$  replaced by  $\sigma_Y$  and  $P$  replaced by  $P_Y$ :

$$\sigma_Y = \frac{P_Y}{A} \left[ 1 + \frac{ec}{r^2} \sec \left( \frac{L_e}{2r} \sqrt{\frac{P_Y}{EA}} \right) \right] \quad (2)$$

Substitute into Eq. (2):

$$42 = \frac{1.8(75 + P_2)}{10.3}$$

$$\left[ 1 + \frac{2.259 P_2}{75 + P_2} \sec(0.08961 \sqrt{75 + P_2}) \right]$$

Solve numerically:  $P_2 = 34.3 \text{ k}$  ←

## Design Formulas for Columns

The problems for Section 11.9 are to be solved assuming that the axial loads are centrally applied at the ends of the columns. Unless otherwise stated, the columns may buckle in any direction.

### STEEL COLUMNS

**Problem 11.9-1** Determine the allowable axial load  $P_{\text{allow}}$  for a W 10  $\times$  45 steel wide-flange column with pinned ends (see figure) for each of the following lengths:  $L = 8$  ft, 16 ft, 24 ft, and 32 ft. (Assume  $E = 29,000$  ksi and  $\sigma_Y = 36$  ksi.)

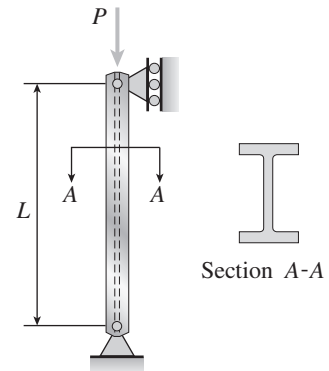

Probs. 11.9-1 through 11.9-6

### Solution 11.9-1 Steel wide-flange column

Pinned ends ( $K = 1$ ).

Buckling about axis 2-2 (see Table E-1).

Use AISC formulas.

W 10  $\times$  45  $A = 13.3$  in.<sup>2</sup>  $r_2 = 2.01$  in.

$E = 29,000$  ksi  $\sigma_Y = 36$  ksi  $\left(\frac{L}{r}\right)_{\text{max}} = 200$

$$\text{Eq. (11-76): } \left(\frac{L}{r}\right)_c = \sqrt{\frac{2\pi^2 E}{\sigma_Y}} = 126.1$$

$$L_c = 126.1 r = 253.5 \text{ in.} = 21.1 \text{ ft}$$

$L$	8 ft	16 ft	24 ft	32 ft
$L/r$	47.76	95.52	143.3	191.0
$n_1$ (Eq. 11-79)	1.802	1.896	–	–
$n_2$ (Eq. 11-80)	–	–	1.917	1.917
$\sigma_{\text{allow}}/\sigma_Y$ (Eq. 11-81)	0.5152	0.3760	–	–
$\sigma_{\text{allow}}/\sigma_Y$ (Eq. 11-82)	–	–	0.2020	0.1137
$\sigma_{\text{allow}}$ (ksi)	18.55	13.54	7.274	4.091
$P_{\text{allow}} = A \sigma_{\text{allow}}$	247 k	180 k	96.7 k	54.4 k

**Problem 11.9-2** Determine the allowable axial load  $P_{\text{allow}}$  for a W 12  $\times$  87 steel wide-flange column with pinned ends (see figure) for each of the following lengths:  $L = 10$  ft, 20 ft, 30 ft, and 40 ft. (Assume  $E = 29,000$  ksi and  $\sigma_Y = 50$  ksi.)

### Solution 11.9-2 Steel wide-flange column

Pinned ends ( $K = 1$ ).

Buckling about axis 2-2 (see Table E-1).

Use AISC formulas.

W 12  $\times$  87  $A = 25.6$  in.<sup>2</sup>  $r_2 = 3.07$  in.

$E = 29,000$  ksi  $\sigma_Y = 50$  ksi  $\left(\frac{L}{r}\right)_{\text{max}} = 200$

$$\text{Eq. (11-76): } \left(\frac{L}{r}\right)_c = \sqrt{\frac{2\pi^2 E}{\sigma_Y}} = 107.0$$

$$L_c = 1.070 r = 328.5 \text{ in.} = 27.4 \text{ ft}$$

$L$	10 ft	20 ft	30 ft	40 ft
$L/r$	39.09	78.18	117.3	156.4
$n_1$ (Eq. 11-79)	1.798	1.892	–	–
$n_2$ (Eq. 11-80)	–	–	1.917	1.917
$\sigma_{\text{allow}}/\sigma_Y$ (Eq. 11-81)	0.5192	0.3875	–	–
$\sigma_{\text{allow}}/\sigma_Y$ (Eq. 11-82)	–	–	0.2172	0.1222
$\sigma_{\text{allow}}$ (ksi)	25.96	19.37	10.86	6.11
$P_{\text{allow}} = A \sigma_{\text{allow}}$	665 k	496 k	278 k	156 k

**Problem 11.9-3** Determine the allowable axial load  $P_{\text{allow}}$  for a W 10 × 60 steel wide-flange column with pinned ends (see figure) for each of the following lengths:  $L = 10$  ft, 20 ft, 30 ft, and 40 ft. (Assume  $E = 29,000$  ksi and  $\sigma_Y = 36$  ksi.)

**Solution 11.9-3 Steel wide-flange column**

Pinned ends ( $K = 1$ ).

Buckling about axis 2-2 (see Table E-1).

Use AISC formulas.

W 10 × 60  $A = 17.6 \text{ in.}^2$   $r_2 = 2.57 \text{ in.}$

$E = 29,000 \text{ ksi}$   $\sigma_Y = 36 \text{ ksi}$   $\left(\frac{L}{r}\right)_{\text{max}} = 200$

$$\text{Eq. (11-76): } \left(\frac{L}{r}\right)_c = \sqrt{\frac{2\pi^2 E}{\sigma_Y}} = 126.1$$

$$L_c = 126.1 r = 324.1 \text{ in.} = 27.0 \text{ ft}$$

$L$	10 ft	20 ft	30 ft	40 ft
$L/r$	46.69	93.39	140.1	186.8
$n_1$ (Eq. 11-79)	1.799	1.894	–	–
$n_2$ (Eq. 11-80)	–	–	1.917	1.917
$\sigma_{\text{allow}}/\sigma_Y$ (Eq. 11-81)	0.5177	0.3833	–	–
$\sigma_{\text{allow}}/\sigma_Y$ (Eq. 11-82)	–	–	0.2114	0.1189
$\sigma_{\text{allow}}$ (ksi)	18.64	13.80	7.610	4.281
$P_{\text{allow}} = A \sigma_{\text{allow}}$	328 k	243 k	134 k	75.3 k

**Problem 11.9-4** Select a steel wide-flange column of nominal depth 10 in. (W 10 shape) to support an axial load  $P = 180$  k (see figure). The column has pinned ends and length  $L = 14$  ft. Assume  $E = 29,000$  ksi and  $\sigma_Y = 36$  ksi. (Note: The selection of columns is limited to those listed in Table E-1, Appendix E.)

**Solution 11.9-4 Select a column of W10 shape**

$P = 180 \text{ k}$   $L = 14 \text{ ft} = 168 \text{ in.}$   $K = 1$

$\sigma_Y = 36 \text{ ksi}$

$E = 29,000 \text{ ksi}$

$$\text{Eq. (11-76): } \left(\frac{L}{r}\right)_c = \sqrt{\frac{2\pi^2 E}{\sigma_Y}} = 126.1$$

(1) TRIAL VALUE OF  $\sigma_{\text{allow}}$

Upper limit: use Eq. (11-81) with  $L/r = 0$

$$\text{max. } \sigma_{\text{allow}} = \frac{\sigma_Y}{n_1} = \frac{\sigma_Y}{5/3} = 21.6 \text{ ksi}$$

Try  $\sigma_{\text{allow}} = 16 \text{ ksi}$

(2) TRIAL VALUE OF AREA

$$A = \frac{P}{\sigma_{\text{allow}}} = \frac{180 \text{ k}}{16 \text{ ksi}} = 11.25 \text{ in.}^2$$

(3) TRIAL COLUMN W 10 × 45

$A = 13.3 \text{ in.}^2$   $r = 2.01 \text{ in.}$

(4) ALLOWABLE STRESS FOR TRIAL COLUMN

$$\frac{L}{r} = \frac{168 \text{ in.}}{2.01 \text{ in.}} = 83.58 \quad \frac{L}{r} < \left(\frac{L}{r}\right)_c$$

Eqs. (11-79) and (11-81):  $n_1 = 1.879$

$$\frac{\sigma_{\text{allow}}}{\sigma_Y} = 0.4153 \quad \sigma_{\text{allow}} = 14.95 \text{ ksi}$$

(5) ALLOWABLE LOAD FOR TRIAL COLUMN

$$P_{\text{allow}} = \sigma_{\text{allow}} A = 199 \text{ k} > 180 \text{ k} \quad (\text{ok})$$

(W 10 × 45)

(6) NEXT SMALLER SIZE COLUMN

W 10 × 30  $A = 8.84 \text{ in.}^2$   $r = 1.37 \text{ in.}$

$$\frac{L}{r} = 122.6 < \left(\frac{L}{r}\right)_c$$

$n = 1.916$   $\sigma_{\text{allow}} = 9.903 \text{ ksi}$

$$P_{\text{allow}} = 88 \text{ k} < P = 180 \text{ k} \quad (\text{Not satisfactory})$$

**Problem 11.9-5** Select a steel wide-flange column of nominal depth 12 in. (W 12 shape) to support an axial load  $P = 175$  k (see figure). The column has pinned ends and length  $L = 35$  ft. Assume  $E = 29,000$  ksi and  $\sigma_Y = 36$  ksi. (Note: The selection of columns is limited to those listed in Table E-1, Appendix E.)

**Solution 11.9-5 Select a column of W12 shape**

$$P = 175 \text{ k} \quad L = 35 \text{ ft} = 420 \text{ in.} \quad K = 1$$

$$\sigma_Y = 36 \text{ ksi} \quad E = 29,000 \text{ ksi}$$

$$\text{Eq. (11-76): } \left(\frac{L}{r}\right)_c = \sqrt{\frac{2\pi^2 E}{\sigma_Y}} = 126.1$$

(1) TRIAL VALUE OF  $\sigma_{\text{allow}}$

Upper limit: use Eq. (11-81) with  $L/r = 0$

$$\text{max. } \sigma_{\text{allow}} = \frac{\sigma_Y}{n_1} = \frac{\sigma_Y}{5/3} = 21.6 \text{ ksi}$$

Try  $\sigma_{\text{allow}} = 8$  ksi (Because column is very long)

(2) TRIAL VALUE OF AREA

$$A = \frac{P}{\sigma_{\text{allow}}} = \frac{175 \text{ k}}{8 \text{ ksi}} = 22 \text{ in.}^2$$

(3) TRIAL COLUMN W 12  $\times$  87

$$A = 25.6 \text{ in.}^2 \quad r = 3.07 \text{ in.}$$

(4) ALLOWABLE STRESS FOR TRIAL COLUMN

$$\frac{L}{r} = \frac{4.20 \text{ in.}}{3.07 \text{ in.}} = 136.8 \quad \frac{L}{r} > \left(\frac{L}{r}\right)_c$$

Eqs. (11-80) and (11-82):  $n_2 = 1.917$

$$\frac{\sigma_{\text{allow}}}{\sigma_Y} = 0.2216 \quad \sigma_{\text{allow}} = 7.979 \text{ ksi}$$

(5) ALLOWABLE LOAD FOR TRIAL COLUMN

$$P_{\text{allow}} = \sigma_{\text{allow}} A = 204 \text{ k} > 175 \text{ k} \quad (\text{ok})$$

(6) NEXT SMALLER SIZE COLUMN

$$\text{W } 12 \times 50 \quad A = 14.7 \text{ in.}^2 \quad r = 1.96 \text{ in.}$$

$\frac{L}{r} = 214$  Since the maximum permissible value of  $L/r$  is 200, this section is not satisfactory.

Select W 12  $\times$  87 ←

**Problem 11.9-6** Select a steel wide-flange column of nominal depth 14 in. (W 14 shape) to support an axial load  $P = 250$  k (see figure). The column has pinned ends and length  $L = 20$  ft. Assume  $E = 29,000$  ksi and  $\sigma_Y = 50$  ksi. (Note: The selection of columns is limited to those listed in Table E-1, Appendix E.)

**Solution 11.9-6 Select a column of W14 shape**

$$P = 250 \text{ k} \quad L = 20 \text{ ft} = 240 \text{ in.} \quad K = 1$$

$$\sigma_Y = 50 \text{ ksi}$$

$$E = 29,000 \text{ ksi}$$

$$\text{Eq. (11-76): } \left(\frac{L}{r}\right)_c = \sqrt{\frac{2\pi^2 E}{\sigma_Y}} = 107.0$$

(1) TRIAL VALUE OF  $\sigma_{\text{allow}}$

Upper limit: use Eq. (11-81) with  $L/r = 0$

$$\text{max. } \sigma_{\text{allow}} = \frac{\sigma_Y}{n_1} = \frac{\sigma_Y}{5/3} = 30 \text{ ksi}$$

Try  $\sigma_{\text{allow}} = 12$  ksi

(2) TRIAL VALUE OF AREA

$$A = \frac{P}{\sigma_{\text{allow}}} = \frac{250 \text{ k}}{12 \text{ ksi}} = 21 \text{ in.}^2$$

(3) TRIAL COLUMN W 14  $\times$  82

$$A = 24.1 \text{ in.}^2 \quad r = 2.48 \text{ in.}$$

(4) ALLOWABLE STRESS FOR TRIAL COLUMN

$$\frac{L}{r} = \frac{240 \text{ in.}}{2.48 \text{ in.}} = 96.77 \quad \frac{L}{r} < \left(\frac{L}{r}\right)_c$$

Eqs. (11-79) and (11-81):  $n_1 = 1.913$

$$\frac{\sigma_{\text{allow}}}{\sigma_Y} = 0.3089 \quad \sigma_{\text{allow}} = 15.44 \text{ ksi}$$

(5) ALLOWABLE LOAD FOR TRIAL COLUMN

$$P_{\text{allow}} = \sigma_{\text{allow}} A = 372 \text{ k} > 250 \text{ k} \quad (\text{ok})$$

(W 14 × 82)

(6) NEXT SMALLER SIZE COLUMN

$$W 14 \times 53 \quad A = 15.6 \text{ in.}^2 \quad r = 1.92 \text{ in.}$$

$$\frac{L}{r} = 125.0 > \left(\frac{L}{r}\right)_c$$

$$n = 1.917 \quad \sigma_{\text{allow}} = 9.557 \text{ ksi}$$

$$P_{\text{allow}} = 149 \text{ k} < P = 250 \text{ k} \quad (\text{Not satisfactory})$$

Select W 14 × 82 ←

**Problem 11.9-7** Determine the allowable axial load  $P_{\text{allow}}$  for a steel pipe column with pinned ends having an outside diameter of 4.5 in. and wall thickness of 0.237 in. for each of the following lengths:  $L = 6$  ft, 12 ft, 18 ft, and 24 ft. (Assume  $E = 29,000$  ksi and  $\sigma_Y = 36$  ksi.)

**Solution 11.9-7 Steel pipe column**Pinned ends ( $K = 1$ ).

Use AISC formulas.

$$d_2 = 4.5 \text{ in.} \quad t = 0.237 \text{ in.} \quad d_1 = 4.026 \text{ in.}$$

$$A = \frac{\pi}{4}(d_2^2 - d_1^2) = 3.1740 \text{ in.}^2$$

$$I = \frac{\pi}{64}(d_2^4 - d_1^4) = 7.2326 \text{ in.}^4$$

$$r = \sqrt{\frac{I}{A}} = 1.5095 \text{ in.} \quad \left(\frac{L}{r}\right)_{\text{max}} = 200$$

$$E = 29,000 \text{ ksi} \quad \sigma_Y = 36 \text{ ksi}$$

$$\text{Eq.(11-76):} \quad \left(\frac{L}{r}\right)_c = \sqrt{\frac{2\pi^2 E}{\sigma_Y}} = 126.1$$

$$L_c = 126.1 r = 190.4 \text{ in.} = 15.9 \text{ ft}$$

$L$	6 ft	12 ft	18 ft	24 ft
$L/r$	47.70	95.39	143.1	190.8
$n_1$ (Eq. 11-79)	1.802	1.896	–	–
$n_2$ (Eq. 11-80)	–	–	1.917	1.917
$\sigma_{\text{allow}}/\sigma_Y$ (Eq. 11-81)	0.5153	0.3765	–	–
$\sigma_{\text{allow}}/\sigma_Y$ (Eq. 11-82)	–	–	0.2026	0.1140
$\sigma_{\text{allow}}$ (ksi)	18.55	13.55	7.293	4.102
$P_{\text{allow}} = A \sigma_{\text{allow}}$	58.9 k	43.0 k	23.1 k	13.0 k

**Problem 11.9-8** Determine the allowable axial load  $P_{\text{allow}}$  for a steel pipe column with pinned ends having an outside diameter of 220 mm and wall thickness of 12 mm for each of the following lengths:  $L = 2.5$  m, 5 m, 7.5 m, and 10 m. (Assume  $E = 200$  GPa and  $\sigma_Y = 250$  MPa.)

**Solution 11.9-8 Steel pipe column**Pinned ends ( $K = 1$ ).

Use AISC formulas.

$$d_2 = 220 \text{ mm} \quad t = 12 \text{ mm} \quad d_1 = 196 \text{ mm}$$

$$A = \frac{\pi}{4}(d_2^2 - d_1^2) = 7841.4 \text{ mm}^2$$

$$I = \frac{\pi}{64}(d_2^4 - d_1^4) = 42.548 \times 10^6 \text{ mm}^4$$

$$r = \sqrt{\frac{I}{A}} = 73.661 \text{ mm} \quad \left(\frac{L}{r}\right)_{\text{max}} = 200$$

$$E = 200 \text{ GPa} \quad \sigma_Y = 250 \text{ MPa}$$

$$\text{Eq.(11-76):} \quad \left(\frac{L}{r}\right)_c = \sqrt{\frac{2\pi^2 E}{\sigma_Y}} = 125.7$$

$$L_c = 125.7 r = 9257 \text{ mm} = 9.26 \text{ m}$$

$L$	2.5 m	5.0 m	7.5 m	10.0 m
$L/r$	33.94	67.88	101.8	135.8
$n_1$ (Eq. 11-79)	1.765	1.850	1.904	–
$n_2$ (Eq. 11-80)	–	–	–	1.917
$\sigma_{\text{allow}}/\sigma_Y$ (Eq. 11-81)	0.5458	0.4618	0.3528	–
$\sigma_{\text{allow}}/\sigma_Y$ (Eq. 11-82)	–	–	–	0.2235
$\sigma_{\text{allow}}$ (MPa)	136.4	115.5	88.20	55.89
$P_{\text{allow}} = A \sigma_{\text{allow}}$	1070 kN	905 kN	692 kN	438 kN